

**2 Lamp  
T5, T5HO, T8, or CFTT5**

**APPLICATION**

- Highly efficient, highly flexible surface mounted luminaire with an upscale architectural appearance.
- Modern, contoured shape provides architectural detail and a “floating” visual effect without dominating the room.
- Excellent visual comfort, ideal for modern high-tech offices.
- Other applications include schools and retail environments.
- Many ballast/lamp systems are available, providing flexibility to tailor the luminaire to specific applications.
- Standard distribution works well for conventional applications, while the wide “batwing” distribution allows wider luminaire spacing and improves uniformity for more even lighting.
- High optical efficiency increases energy savings.
- Step dimming ballasts can be switched to less than 50% input power for energy savings to meet most energy codes while maintaining symmetrical illumination.
- Multiple shielding options create a wide variety of photometric variations and aesthetic effects.

- Wireway cover is easily removable without tools for quick ballast or wiring access from below.
- Matte white external finish is standard, custom colors available.
- Approximate weight 30lbs.

**ELECTRICAL**

- UL listed for damp locations. Canadian certified optional.
- Standard size fluorescent emergency ballasts can be incorporated in some models, UL listed for dry locations.
- Systems are available offering electrical system efficacy ratings up to 85 Lumens/Watt.

**ENCLOSURES**

- One-piece enclosure hinges down as an assembly for easy access to lamps and ballast from below.
- T-hinges provide secure retention of enclosure and eliminate non-captive parts to hold during servicing.
- Guide-post spring loaded latches allow easy opening and closing of the enclosure.
- Choice of shielding includes diffuse acrylic with or without overlay, white radial louver with overlay, round or linear perforated steel with overlay.

**CONSTRUCTION/FINISH**

- Extruded aluminum external construction provides accurate, high quality fit and finish.

**CATALOG NUMBER**



WIDTH	FAMILY	DISTRIBUTION	NO. OF LAMPS	DIFFUSERS	BALLAST CONFIG.	BALLAST TYPE	OPTIONS
2 - 2'	SAT - Surface Attune	N - Standard W - Wide (Batwing)*  * Not available with CF40/CF50/CF55	(not included) 2	D - Diffuse DO - Diffuse w/overlay WO - White Radial Louver w/overlay PMW - Round Perf. w/white overlay SMW - Slotted (Linear) Perf. w/white overlay	1/2 - One 2-lamp ballast	EBD - T5/T5HO/T8/CF electronic dimming ballast EB - T5/T5HO/T8/CF electronic ballast, std. ballast factor EBL - T8 Electronic ballast, low ballast factor EBH - T8 Electronic ballast, hi ballast factor EB10I - T8 Electronic ballast, <10% THD, instant start EB10R - T8 Electronic ballast, <10% THD, rapid start EBS - T8 Electronic ballast EBSD - T8 Electronic step dimming ballast EBS095 - 14wT5 Electronic step dimming ballast, .95 ballast factor EBS0115 - 14wT5 Electronic step dimming ballast, 1.15 ballast factor	CM - Canadian Market CC - Custom Color E1* - DEB-1 emerg. ballast, T8 lamps, 350-450 lumens E7* - DEB-7 emerg. ballast, T8 lamps, 600-700 lumens GLR# - Fusing, fast blow (# = number of ballasts) LPT730 - Installed T8 lamps, 70+ CRI, 3000K LPT735 - Installed T8 lamps, 70+ CRI, 3500K LPT741 - Installed T8 lamps, 70+ CRI, 4100K LPT830HL - Installed T8 hi lumen lamps, 80+ CRI, 3000K LPT835HL - Installed T8 hi lumen lamps, 80+ CRI, 3500K LPT841HL - Installed T8 hi lumen lamps, 80+ CRI, 4100K LPT830 - Installed T8/T5/T5HO lamps, 80+ CRI, 3000K LPT835 - Installed T8/T5/T5HO lamps, 80+ CRI, 3500K LPT841 - Installed T8/T5/T5HO lamps, 80+ CRI, 4100K

\*Factory Installed

**JOB INFORMATION**

**0147-AR**

**ENERGY DATA**

Lamp Type	Ballast Type	Input Power (120/277V)	Electrical System Lumens/Watt	
			Std. Lamps*	Hi-lumen Lamps
14	EB	34W / 34W	84	–
	EBSD95@hi	35W / 35W	77	–
	EBSD95@lo	16W / 16W	62	–
	EBSD115@hi	38W / 37W	84	–
	EBSD115@lo	18W / 19W	57	–
17	EB	34W / 34W	76	86
	high eff. EB	30W / 30W	80	<b>90</b>
	EB10I	33W / 33W	75	85
	EB10R	34W / 34W	74	84
	EBL	30W / 30W	76	86
	EBH	43W / 43W	78	88
	EBSD@hi	30W / 30W	77	87
	EBSD@lo	16W / 16W	50	57
24HO	EB	53W / 52W	77	–
CF40	EB	76W / 73W	79	–
CF50	EB	106W / 106W	85	–
CF55	EB	112W / 109W	79	–

\*T8 values assume 70+CRI lamp. 80+CRI lamps with increased lumen ratings are also available.

**DIMENSIONS**

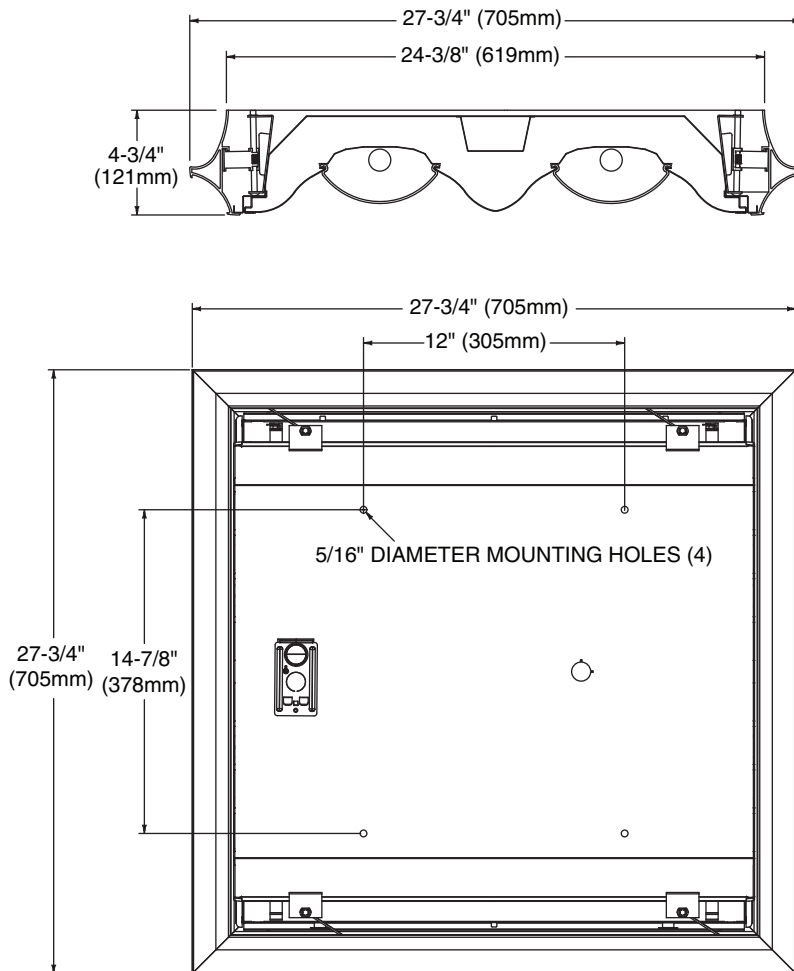

PHOTOMETRIC DATA

CATALOG # 2SATW214-D-1/2-EB  
TEST #25599 S/MH=1.5

LAMPS = F14T5  
BALLAST = ELECTRONIC

INPUT WATTS = 34  
BALLAST FACTOR = 1.00

LER = 62

COMPARATIVE YEARLY LIGHTING ENERGY COST PER 1000 LUMENS = \$3.87 BASED ON 3000 HRS. AND \$.08 PER KWH.

FIXTURE EFFICIENCY= 87.8%

T5 WIDE, DIFFUSE

CANDLEPOWER				
Angle	End	45	Cross	
0	716	716	716	
5	716	718	718	
10	706	722	738	
15	688	726	763	
20	663	725	774	
25	631	713	769	
30	594	688	745	
35	545	649	701	
40	493	598	644	
45	436	537	578	
50	374	473	511	
55	310	403	434	
60	251	334	353	
65	191	260	254	
70	138	182	154	
75	91	110	77	
80	48	51	35	
85	16	14	9	

MAINTAINED ILLUMINATION TABLE- Square Feet/Fixture*			
<ul style="list-style-type: none"> <li>80-50-20 Reflectances (Ceiling-Wall-Floor)</li> <li>LLF = 0.89 1200 Lumens/Lamp very clean</li> <li>Room width divided by room height = 5 or more, 2 or 1</li> </ul>			
Fixture Size & # of Lamps	Room Width Room Height =	Approx. Area (sq. ft.) per Fixture	
		30 ft-c	50 ft-c
2x2	5	66	39
T5 Wide	2	45	-
Diffuse	1	33	-

\*Observe Fixture S/MH Requirements for Specific Applications

COEFFICIENT OF UTILIZATION						
pfc pcc pw RCR	20		70		50	
	70	50	30	70	50	30
0	105	105	105	102	102	97
1	95	92	89	93	90	86
2	88	81	75	84	79	73
3	80	70	64	78	69	67
4	72	63	56	70	61	55
5	68	56	48	66	55	47
6	61	51	42	60	50	42
7	57	46	38	56	45	38
8	54	41	34	52	40	34
9	50	39	30	48	38	30
10	46	35	28	46	34	28

LIGHT DISTRIBUTION			
DEGREES	LUMENS	% LAMP	% FIXTURE
0-30	599	25.0	28.4
0-40	996	41.5	47.3
0-60	1745	72.7	82.3
0-90	2107	87.8	100.0

.89LLF = .94LDD x .94LLD x 1.0BF

PHOTOMETRIC DATA

CATALOG # 2SATN214-D-1/2-EB  
TEST #25582 S/MH=1.2

LAMPS = F14T5  
BALLAST = ELECTRONIC

INPUT WATTS = 33  
BALLAST FACTOR = 1.00

LER = 66

COMPARATIVE YEARLY LIGHTING ENERGY COST PER 1000 LUMENS = \$3.64 BASED ON 3000 HRS. AND \$.08 PER KWH.

FIXTURE EFFICIENCY= 91.0%

T5 STANDARD, DIFFUSE

CANDLEPOWER				
Angle	End	45	Cross	
0	968	968	968	
5	964	963	961	
10	945	948	950	
15	915	923	927	
20	871	885	883	
25	817	831	829	
30	749	770	762	
35	672	692	693	
40	589	610	613	
45	502	527	534	
50	418	446	452	
55	339	368	359	
60	263	293	249	
65	196	215	155	
70	138	139	97	
75	88	82	60	
80	47	43	33	
85	16	14	9	

MAINTAINED ILLUMINATION TABLE- Square Feet/Fixture*			
<ul style="list-style-type: none"> <li>80-50-20 Reflectances (Ceiling-Wall-Floor)</li> <li>LLF = 0.89 1200 Lumens/Lamp very clean</li> <li>Room width divided by room height = 5 or more, 2 or 1</li> </ul>			
Fixture Size & # of Lamps	Room Width Room Height =	Approx. Area (sq. ft.) per Fixture	
		30 ft-c	50 ft-c
2x2	5	68	41
T5 Standard	2	48	-
Diffuse	1	36	-

\*Observe Fixture S/MH Requirements for Specific Applications

COEFFICIENT OF UTILIZATION						
pfc pcc pw RCR	20		70		50	
	70	50	30	70	50	30
0	108	108	108	106	106	101
1	100	95	93	97	93	91
2	92	84	80	90	83	78
3	84	76	68	81	73	68
4	78	68	59	76	67	59
5	71	60	53	69	59	53
6	67	55	47	65	55	46
7	61	50	42	60	50	42
8	57	46	39	56	46	39
9	54	42	34	53	41	34
10	51	39	33	50	39	32

LIGHT DISTRIBUTION			
DEGREES	LUMENS	% LAMP	% FIXTURE
0-30	732	30.5	33.5
0-40	1161	48.4	53.2
0-60	1885	78.5	86.3
0-90	2183	91.0	100.0

.89LLF = .94LDD x .94LLD x 1.0BF

PHOTOMETRIC DATA

CATALOG # 2SATW217-D-1/2-EB  
TEST #25545 S/MH=1.6

LAMPS = F1T8  
BALLAST = ELECTRONIC

INPUT WATTS = 35  
BALLAST FACTOR = 0.88

LER = 49

COMPARATIVE YEARLY LIGHTING ENERGY COST PER 1000 LUMENS = \$4.90 BASED ON 3000 HRS. AND \$.08 PER KWH.

FIXTURE EFFICIENCY= 74.1%

T8 WIDE, DIFFUSE

CANDLEPOWER				
Angle	End	45	Cross	
0	634	634	634	
5	636	632	632	
10	627	632	642	
15	612	631	656	
20	590	627	667	
25	563	619	675	
30	528	604	674	
35	488	581	660	
40	444	551	636	
45	393	511	597	
50	342	463	544	
55	287	406	460	
60	233	342	342	
65	181	261	227	
70	132	173	134	
75	86	98	69	
80	48	45	34	
85	16	12	8	

MAINTAINED ILLUMINATION TABLE- Square Feet/Fixture*			
<ul style="list-style-type: none"> <li>80-50-20 Reflectances (Ceiling-Wall-Floor)</li> <li>LLF = 0.77 1325 Lumens/Lamp very clean</li> <li>Room width divided by room height = 5 or more, 2 or 1</li> </ul>			
Fixture Size & # of Lamps	Room Width Room Height =	Approx. Area (sq. ft.) per Fixture	
		30 ft-c	50 ft-c
2x2	5	53	32
T8 Wide	2	36	-
Diffuse	1	-	-

\*Observe Fixture S/MH Requirements for Specific Applications

COEFFICIENT OF UTILIZATION						
pfc pcc pw RCR	20		70		50	
	70	50	30	70	50	30
0	88	88	88	85	85	81
1	81	78	75	79	76	72
2	73	68	63	71	67	61
3	67	59	54	65	58	53
4	61	53	46	59	52	46
5	56	46	40	55	46	40
6	52	41	35	51	41	34
7	47	38	32	46	38	30
8	45	34	28	44	34	28
9	41	32	26	40	30	25
10	39	28	23	38	28	23

LIGHT DISTRIBUTION			
DEGREES	LUMENS	% LAMP	% FIXTURE
0-30	525	19.8	26.7
0-40	886	33.4	45.1
0-60	1618	61.1	82.4
0-90	1963	74.1	100.0

.77LLF = .94LDD x .93LLD x .88BF

**PHOTOMETRIC DATA**

CATALOG # 2SATN217-D-1/2-EB  
TEST #25531 S/MH=1.2

LAMPS = F17T8  
BALLAST = ELECTRONIC

INPUT WATTS = 35  
BALLAST FACTOR = 0.88

LER = 52

COMPARATIVE YEARLY LIGHTING ENERGY COST PER 1000 LUMENS = \$4.62 BASED ON 3000 HRS. AND \$.08 PER KWH.

FIXTURE EFFICIENCY= 77.5%

T8 STANDARD, DIFFUSE

CANDLEPOWER				
Angle	End	45	Cross	
0	902	902	902	
5	901	894	893	
10	884	878	879	
15	855	851	853	
20	813	814	819	
25	760	765	776	
30	696	708	721	
35	630	647	665	
40	552	578	589	
45	474	503	512	
50	396	427	431	
55	321	353	333	
60	252	280	231	
65	188	202	145	
70	131	130	92	
75	86	77	58	
80	46	40	32	
85	16	13	9	

MAINTAINED ILLUMINATION TABLE- Square Feet/Fixture*			
<ul style="list-style-type: none"> <li>80-50-20 Reflectances (Ceiling-Wall-Floor)</li> <li>LLF = 0.77 1325 Lumens/Lamp very clean</li> <li>Room width divided by room height = 5 or more, 2 or 1</li> </ul>			
Fixture Size & # of Lamps	Room Width Room Height =	Approx. Area (sq. ft.) per Fixture	
		30 ft-c	50 ft-c
2x2	5	56	33
T5 Standard	2	39	-
Diffuse	1	-	-

\*Observe Fixture S/MH Requirements for Specific Applications

.77LLF = .94LDD x .93LLD x .88BF

COEFFICIENT OF UTILIZATION						
ptc pcc pw RCR	20		70		50	
	70	50 30	70	50 30	50	30
0	92	92	90	90	85	85
1	84	81	79	82	80	77
2	78	72	68	76	70	68
3	71	64	58	69	63	56
4	66	57	51	65	56	51
5	60	52	45	59	51	45
6	56	46	40	55	46	40
7	53	42	35	51	41	35
8	48	39	33	47	39	33
9	46	35	29	45	35	29
10	42	33	28	41	33	27

LIGHT DISTRIBUTION			
DEGREES	LUMENS	% LAMP	% FIXTURE
0-30	679	25.6	33.1
0-40	1082	40.8	52.7
0-60	1770	66.8	86.2
0-90	2053	77.5	100.0

**PHOTOMETRIC DATA**

CATALOG # 2SATN2CF40-D-1/2-EB  
TEST #25739 S/MH= 1.1

LAMPS = 40wT5  
BALLAST = ELECTRONIC

INPUT WATTS = 67  
BALLAST FACTOR = 0.88

LER = 66

COMPARATIVE YEARLY LIGHTING ENERGY COST PER 1000 LUMENS = \$3.64 BASED ON 3000 HRS. AND \$.08 PER KWH.

FIXTURE EFFICIENCY= 79.6%

CFTT5, DIFFUSE

CANDLEPOWER				
Angle	End	45	Cross	
0	2240	2240	2240	
5	2241	2213	2228	
10	2198	2167	2178	
15	2134	2094	2101	
20	2030	1995	1992	
25	1906	1866	1868	
30	1751	1715	1718	
35	1585	1559	1564	
40	1410	1378	1396	
45	1213	1204	1209	
50	1018	1019	1024	
55	826	847	796	
60	651	679	546	
65	487	499	354	
70	345	320	223	
75	220	194	141	
80	119	100	77	
85	42	32	22	

MAINTAINED ILLUMINATION TABLE- Square Feet/Fixture*			
<ul style="list-style-type: none"> <li>80-50-20 Reflectances (Ceiling-Wall-Floor)</li> <li>LLF = 0.75 3150 Lumens/Lamp very clean</li> <li>Room width divided by room height = 5 or more, 2 or 1</li> </ul>			
Fixture Size & # of Lamps	Room Width Room Height =	Approx. Area (sq. ft.) per Fixture	
		30 ft-c	50 ft-c
2x2	5	132	79
CF40 Standard	2	93	56
Diffuse	1	69	41

\*Observe Fixture S/MH Requirements for Specific Applications

.75LLF = .94LDD x .90LLD x .88BF

COEFFICIENT OF UTILIZATION						
ptc pcc pw RCR	20		70		50	
	70	50 30	70	50 30	50	30
0	94	94	94	93	93	88
1	88	83	81	85	81	79
2	80	75	69	78	72	69
3	73	66	59	71	65	57
4	68	58	53	66	57	52
5	63	53	46	60	52	46
6	57	47	41	56	47	40
7	54	44	36	53	42	36
8	51	40	34	48	40	34
9	46	36	30	46	36	30
10	44	34	28	42	34	28

LIGHT DISTRIBUTION			
DEGREES	LUMENS	% LAMP	% FIXTURE
0-30	1665	26.4	33.2
0-40	2642	41.9	52.7
0-60	4312	68.4	86.0
0-90	5016	79.6	100.0

 The photometric results were obtained in the Day-Brite Lighting Laboratory which is NVLAP accredited by the National Institute of Standards and Technology.